

1U Passive Optical Fiber Expansion Equipment

5G Base Station Remote Expansion System



Specification

As the deployment of wireless networks becomes more and more intensive, the scale of large-capacity distributed base stations is also expanding. The deep coverage of base stations requires the location of the deployment to be closer to users. The passive optical fiber expander utilizes the characteristics of a single optical fiber that can transmit multiple optical carriers of different wavelengths at the same time. It effectively solves the problem of the lack of optical fiber cable resources between BBU and RRU/DU and AAU in the C-RAN architecture, and meets the requirements for deep coverage and flexible expansion of carrier base stations.

Functions and features

- Supporting CWDM/DWDM.
- Low insertion loss and high channel isolation.
- Supporting upgrade and expansion.
- Optical wavelength customization.
- High reliability and stability.
- Waterproof, dustproof and resistant to high and low temperatures, no power is required.

Parameters

System Parameter	Technical Index	
Optical fiber expansion capacity	Single fiber bidirectional: The maximum capacity of fiber can be expanded by 9 times. Dual fiber bidirectional: The maximum capacity of fiber can be expanded by 18 times.	
Insertion loss	The insertion loss introduced by the devices at both ends is less than 2~5 (dB); it depends on the capacity expansion.	
Access business types	It can access optical signals including SDH, Ethernet, FC, PON, CPRI and other formats.	
Transmission distance	0~40KM.	
Operation environment	Working temperature	-10°C ~ +70°C or -40°C ~ +80°C.
	Working humidity	5%~95%.
Connector type	LC, FC, SC, etc. (optional)	
MTBF	130000 hours.	
Device Dimension	1U chassis	438mm (W) ×44mm (H) ×230mm (D).
	Card type	25mm (W) ×130mm (H) ×100mm (D).
	Card with chassis	438mm (W) ×132mm (H) ×110mm (D).
Weight	1U chassis	≤5KG.
	Card type	≤0.2KG.
	Card with chassis	≤7KG.

Networking Applications

The base station remote product effectively solves the practical problem of lack of fiber-optic cable transmission resources between BBU-RRU/DU-AAU in C-RAN architecture, and meets the requirements of deep coverage and flexible expansion of carrier base stations. Moreover, it can provide multi-solutions for full scene access and end-to-end loading.

Application 1: Passive Solution

Passive solutions need to deploy passive optical fiber expansion equipment between BBU/DU pool and RRU/AAU. Only one pair of optical fibers is required between the passive optical fiber expansion equipment. At the same time, we need to replace the SFP colored optical module provided by our company at the CRU port of RRU/AAU and BBU/DU.

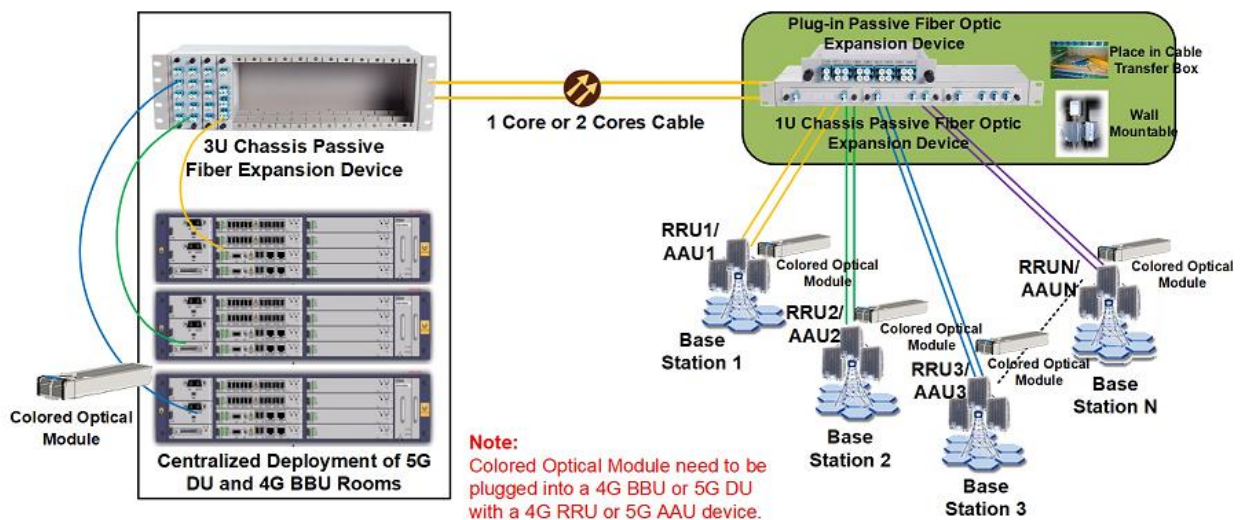

Figure 1: Passive Application Solution for BBU/DU & RRU/AAU

Application 2: Active Solution

Active solutions need to deploy active optical fiber expansion devices between BBU/DU pool and RRU/AAU. Only one pair of optical fibers is required between the active optical fiber expansion devices, and the original BBU/DU devices and RRU/AAU devices do not need to be changed. Plug-and-play, it supports mixed transmission of other types of services.

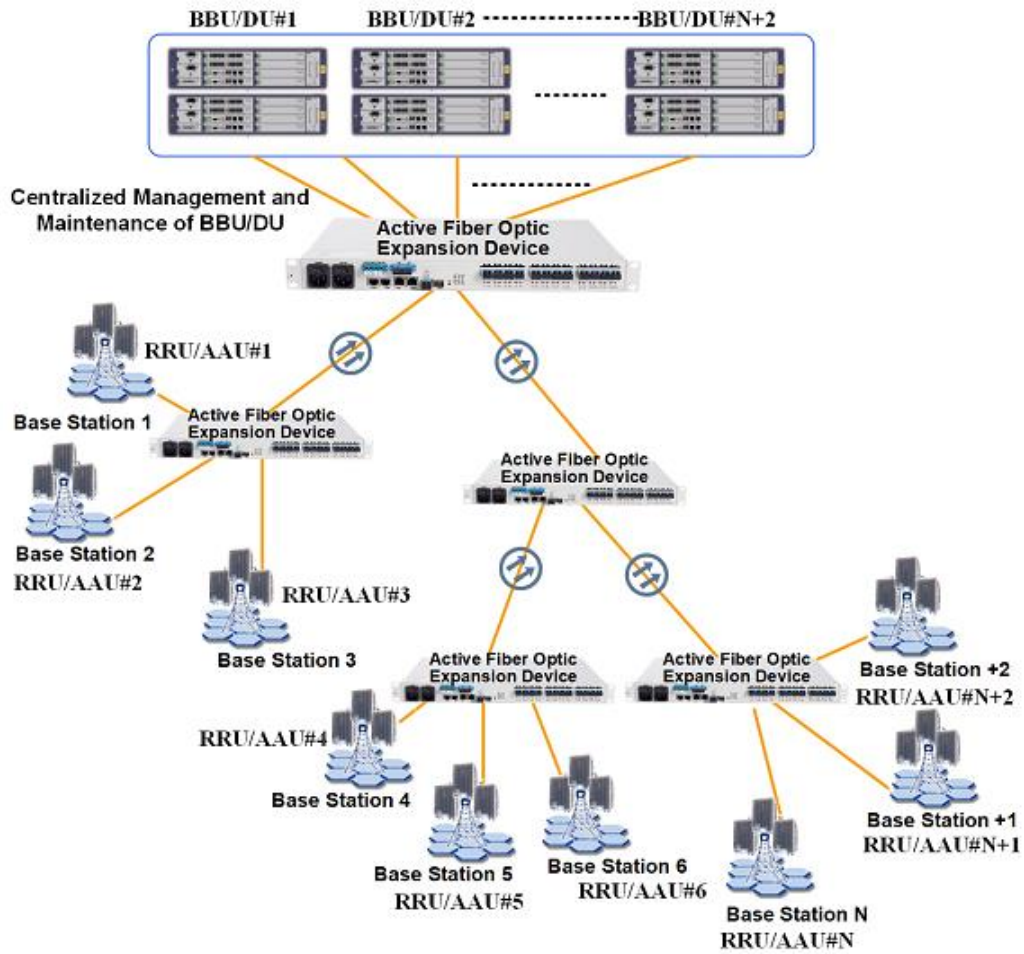

Figure 2: Active Application Solution for BBU/DU & RRU/AAU